

- LEGEND:**
- W — Water
 - SAN — Sanitary Sewer
 - STM — Storm Sewer
 - G — Gas
 - ET — Electrical/Telephone
 - CTV — Cable TV

NOTE:
Right of way width, back to back of curb dimensions, and green strip width shown above are based upon local road section.

TYPICAL LOT UTILITY LOCATION
NOT TO SCALE

GENERAL NOTES:
1.) The location of proposed utilities as indicated hereon are based upon the orderly development of the land. Strict adherence to the indicated location is required. Requests to change the location of the proposed utilities shall be submitted in writing to the Public Works Commissioner. Utilities not meeting these requirements shall be removed and replaced as directed by the Public Works Commissioner at the owner's expense.

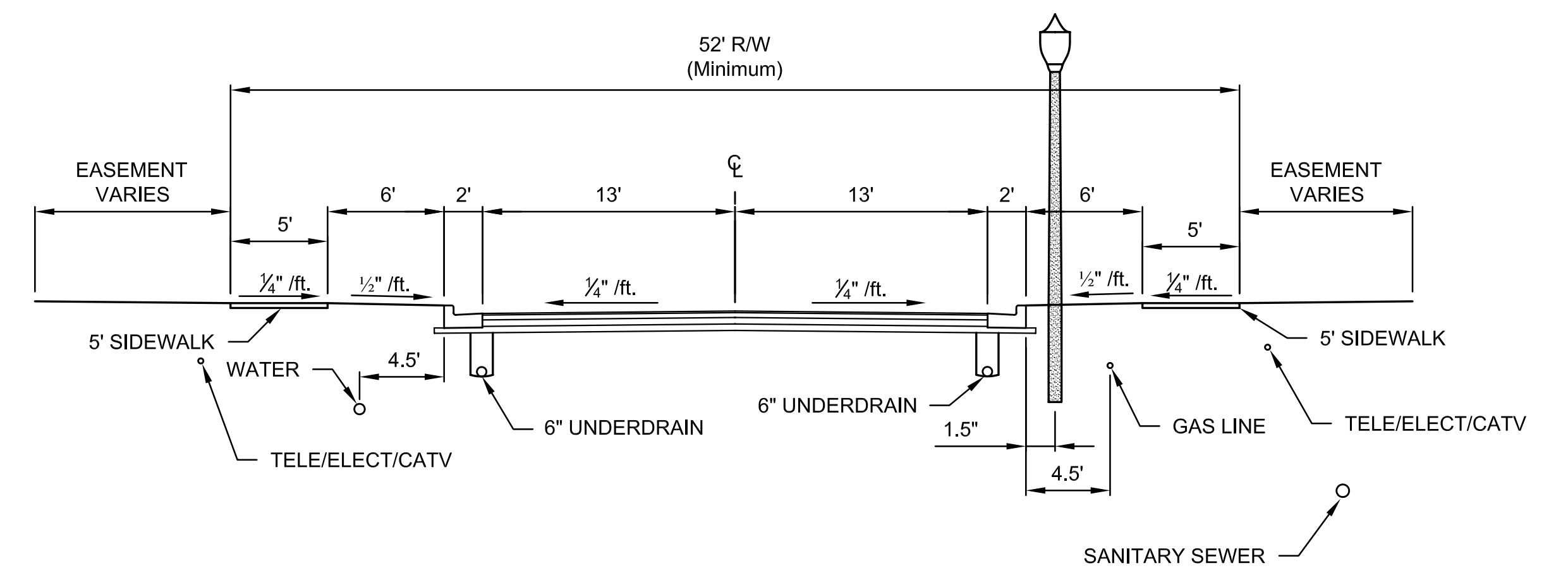

TYPICAL LOCAL ROAD UTILITY LOCATION
NOT TO SCALE

REVISIONS		
REV. NO.	DESCRIPTION	DATE



RECOMMEND FOR APPROVAL: *Mark J. Witsman* DESIGN ENGINEER 7/12/05 DATE

APPROVED: *Ronald D. Coe* PUBLIC WORKS COMMISSIONER 7/12/05 DATE

APPROVED: *Mark J. Witsman* TOWN COUNCIL PRESIDENT 7/12/05 DATE

TOWN OF McCORDSVILLE

TOWN STANDARDS
UTILITY LOCATION
GUIDELINES

SHEET
4
OF
10